

AXR-110 Contactless Reader



Product description:

The AXR-110 Reader is intended for reading contactless (RFID) identifiers of technologies working on frequency of 13.56 MHz.

There is a color LED on the front side of the Reader. This LED informs about reading the identifier in connection with a sound signalization (beeper).

In total the LED signalization indicates 3 states:

- 1) Blue - Idle
- 2) Green – Access Granted
- 3) Red – Access Denied

The Reader can be added to Aktion controllers or terminals, in case of need it can be added to other producers' devices¹⁾. The beeper and the LED are operated directly from a controller or a terminal. It is possible to connect them through for signalization of alarming states (e. g. opening a door over the pre-set limit, penetration etc.).

Technical specification:

Rated power supply	12 VDC
Max. current requirements	75 mA
Data interface	Wiegand 42bite (5Byte)
Reading range – ISO card	Max. 2.8"/7cm ^{2) 3)}
Reading range – clip	Max. 1.4"/3,5cm ^{2) 3)}
Reading range – combination card	Max. 1.4"/3,5cm ^{2) 3)}
Frequency	13.56 MHz
Reader type	Read only
Sound signalization	Buzzer
Optical signalization	LED (blue, green, red)
Cable length	Shifting-on staple, type MRT8 P3.5/9
Reader dimensions (W x H x D)	1.65 "x 4.7 "x 1.6 " / 42 x 120 x 40 mm
Top cover dimensions (W x H x D)	1.8 "x 4.9 " x 1.6 " / 45 x 124 x 41 mm
Operating temperature	-4 to 122 °F; -20 to +50 °C
Environmental	IP 54 ⁴⁾

Color versions of top covers:

H-100/B	Top cover AXR-100, black
H-100/W	Top cover AXR-100, white
H-100/G	Top cover AXR-100, grey
H-100/T	Top cover AXR-100, titan
H-100/R	Top cover AXR-100, red

¹⁾ A way of connection and functions haven't been tested so they can differ from the Aktion system.

²⁾ It was measured for original identifiers. Other ID types can have a different reading range.

³⁾ It was measured on a nonmetal undersurface. A metal undersurface can decrease a reading range.

⁴⁾ Holding to the right assembly process is required for the declared environmental.

Drawing:

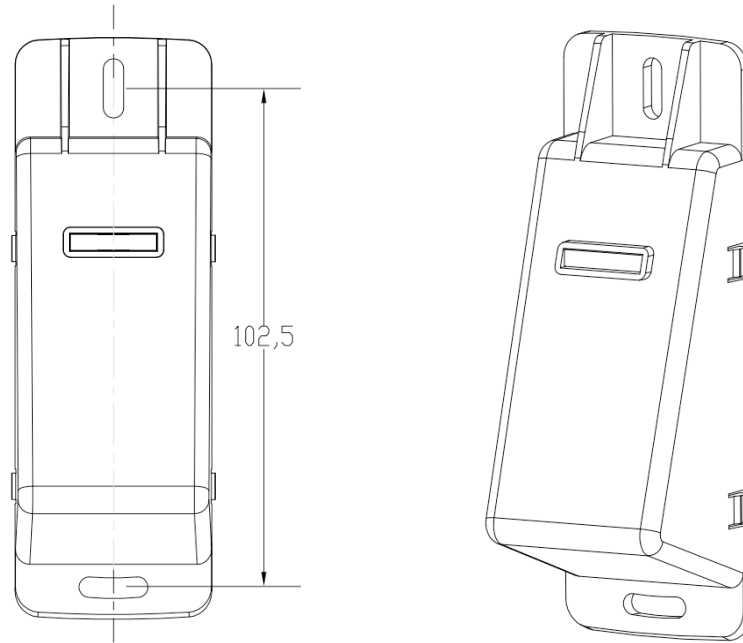

The Installation:

Advised height for a location of the reader is 120 cm between the ground and the reader bottom part.

The Installation process:

- 1) Drill slots for mounting the reader on an undersurface – spacing according to the drawing
- 2) Next drill a slot for the incoming cable into undersurface
- 3) Install the incoming cable and screw a shifting-on connector of the reader onto the cable
- 4) Plug the cable with a connector in a socket of the reader
- 5) Fasten the reader onto undersurface by enclosed connecting material
- 6) Put top colored cover on the reader

Conductors and pins description:

Connector PIN	Function	Description
1	TAMPER	Protective loop, connected to pin n. 2 inside of the reader
2	TAMPER	Protective loop, connected to pin n. 1 inside of the reader
3	GND	The ground of power supply
4	+ 12VDC	Positive pole of power supply
5	GLED	Green LED
6	RLED	Red LED
7	BEEP	Beeper
8	D10(D20)	Data conductor D0 Wiegand data interface
9	D11(D21)	Data conductor D1 Wiegand data interface

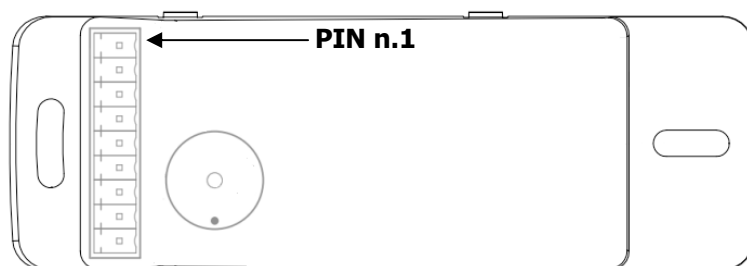

Wiegand Data Interface Description:

AXR-100 Readers are commonly supplied in formats of Wiegand 42bite.

Format 42bite (5Byte):

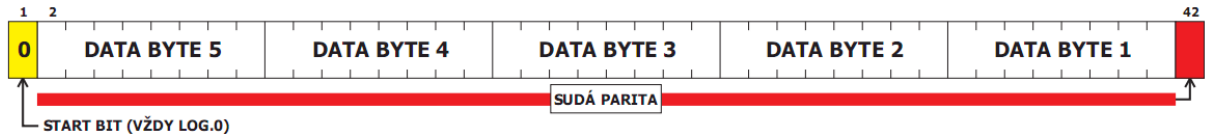

Time flow of Wiegand Data Interface:

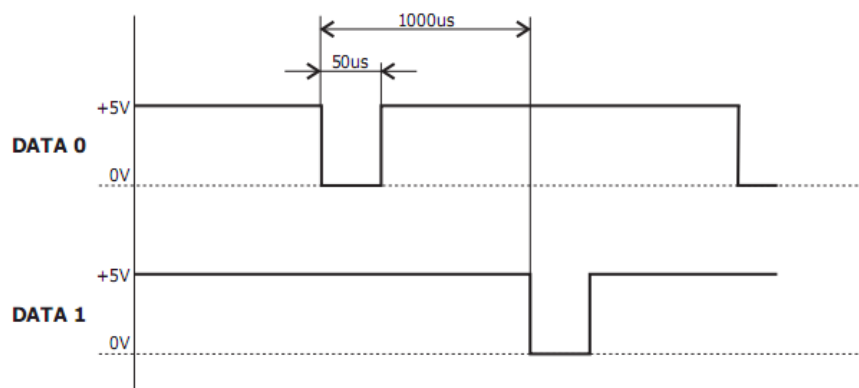

Supported types of contactless identifiers:

Standard	Identifier type
ISO 14443A	MIFARE® (only CSN*) DESFire® (only CSN*)

*) reading of an unique serial card code